

# Three Phase Rectifier Bridge

**$I_{dAV} = 127 \text{ A}$**   
 **$V_{RRM} = 800-1800 \text{ V}$**

$V_{RSM}$ V	$V_{RRM}$ V	Type
800	800	VUO 110-08NO7
1200	1200	VUO 110-12NO7
1400	1400	VUO 110-14NO7
1600	1600	VUO 110-16NO7
1800	1800	VUO 110-18NO7*

\* delivery time on request

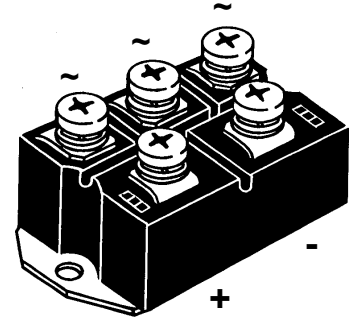
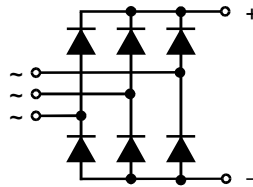

Symbol	Test Conditions	Maximum Ratings	
$I_{dAV}$	$T_C = 100^\circ\text{C}$ , module	127	A
$I_{dAV}$	$T_A = 35^\circ\text{C}$ ( $R_{thCA} = 0.2 \text{ K/W}$ ), module	118	A
$I_{FSM}$	$T_{VJ} = 45^\circ\text{C}$ ; $V_R = 0$	$t = 10 \text{ ms}$ (50 Hz), sine	1200 A
		$t = 8.3 \text{ ms}$ (60 Hz), sine	1300 A
$I^2t$	$T_{VJ} = T_{VJM}$ ; $V_R = 0$	$t = 10 \text{ ms}$ (50 Hz), sine	1000 A <sup>2</sup> s
		$t = 8.3 \text{ ms}$ (60 Hz), sine	1100 A <sup>2</sup> s
$I^2t$	$T_{VJ} = 45^\circ\text{C}$ ; $V_R = 0$	$t = 10 \text{ ms}$ (50 Hz), sine	7200 A <sup>2</sup> s
		$t = 8.3 \text{ ms}$ (60 Hz), sine	7200 A <sup>2</sup> s
$I^2t$	$T_{VJ} = T_{VJM}$ ; $V_R = 0$	$t = 10 \text{ ms}$ (50 Hz), sine	5000 A <sup>2</sup> s
		$t = 8.3 \text{ ms}$ (60 Hz), sine	5000 A <sup>2</sup> s
$T_{VJ}$		-40...+150	°C
$T_{VJM}$		150	°C
$T_{stg}$		-40...+125	°C
$V_{ISOL}$	50/60 Hz, RMS $I_{ISOL} \leq 1 \text{ mA}$	$t = 1 \text{ min}$	2500 V~
		$t = 1 \text{ s}$	3000 V~
$M_d$	Mounting torque (M6)	$5 \pm 15 \%$	Nm
	Terminal connection torque (M6)	$5 \pm 15 \%$	Nm
Weight	typ.	270	g

### Features

- Package with screw terminals
- Isolation voltage 3000 V~
- Planar passivated chips
- Blocking voltage up to 1800 V
- Low forward voltage drop
- UL registered E72873

### Applications

- Supplies for DC power equipment
- Input rectifiers for PWM inverter
- Battery DC power supplies
- Field supply for DC motors

### Advantages

- Easy to mount with two screws
- Space and weight savings
- Improved temperature and power cycling

### Dimensions in mm (1 mm = 0.0394")

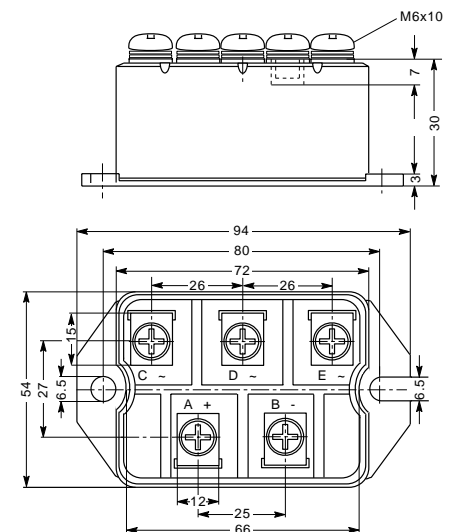

Symbol	Test Conditions	Characteristic Values	
$I_R$	$V_R = V_{RRM}^*$ ; $V_R = V_{RRM}^*$	$T_{VJ} = 25^\circ\text{C}$	$\leq 0.3 \text{ mA}$
		$T_{VJ} = T_{VJM}$	$\leq 5 \text{ mA}$
$V_F$	$I_F = 300 \text{ A}$ ; $T_{VJ} = 25^\circ\text{C}$	$\leq 1.9$	V
$V_{T0}$	For power-loss calculations only	0.8	V
$r_T$		4	mΩ
$R_{thJC}$	per diode	0.9	K/W
	per module	0.15	K/W
$R_{thJH}$	per diode	1.08	K/W
	per module	0.18	K/W
$d_s$	Creeping distance on surface	10	mm
$d_A$	Creepage distance in air	9.4	mm
$a$	Max. allowable acceleration	50	m/s <sup>2</sup>

Data according to IEC 60747 and refer to a single diode unless otherwise stated  
 IXYS reserves the right to change limits, test conditions and dimensions.